

FRONT
SCALE 1 / 2

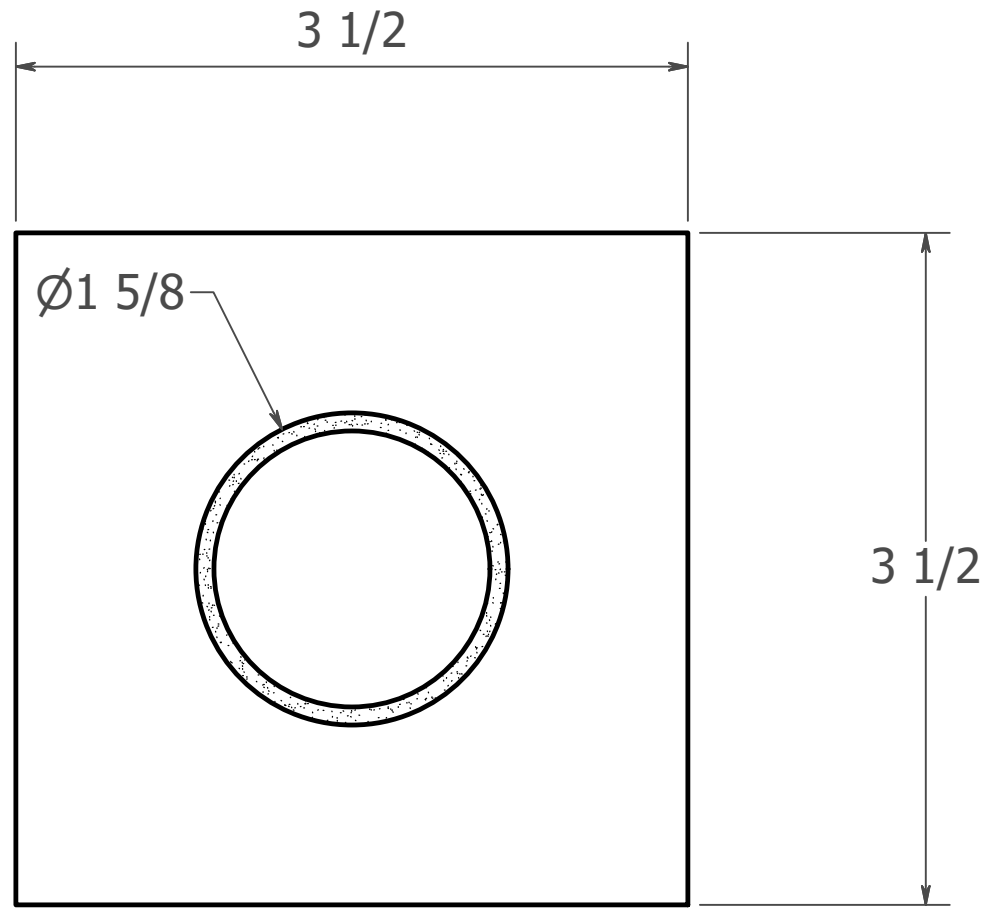

SECTION A-A
SCALE 1 : 1

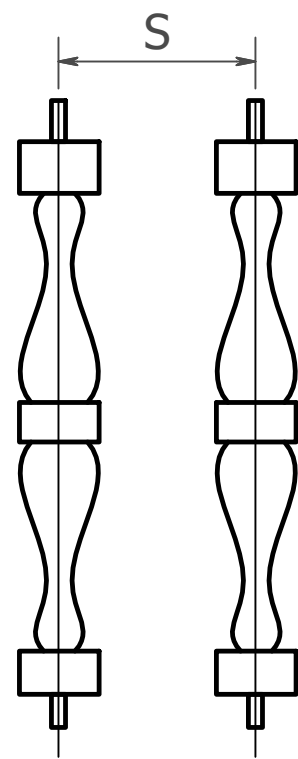

DISTANCE BETWEEN
BALUSTERS = S

S = 5.875

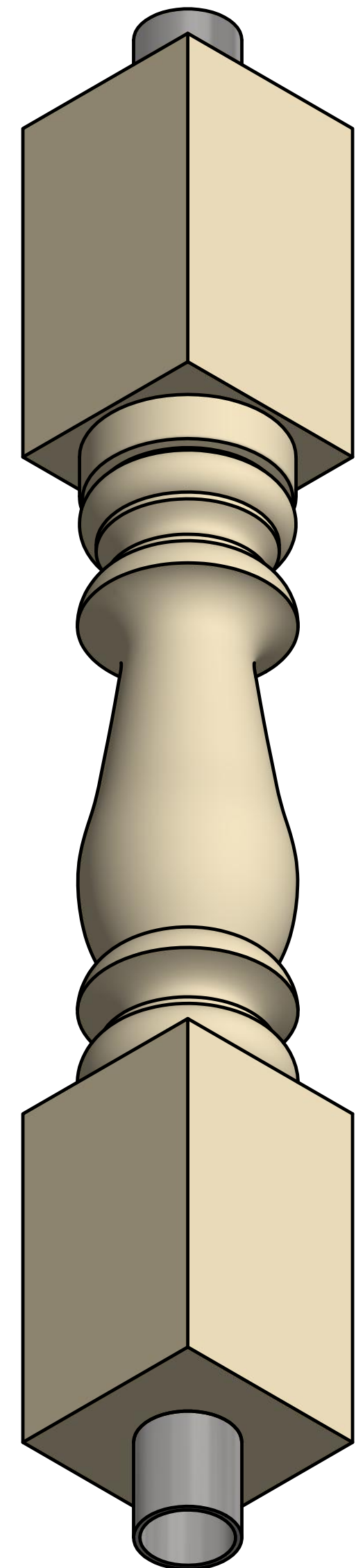

3D
SCALE 1 / 2

NOTE 1: MEASUREMENTS TAKEN FROM PRODUCTION PARTS.
DRAWINGS MAY VARY SLIGHTLY FROM ACTUAL PARTS.

REV	DESCRIPTION	DATE	APVD.